



An 800-2400 MC Signal Generator with Automatically-Leveled Output Power

SOME years ago -hp- introduced a series of broadband microwave signal generators which were designed with direct-reading RF controls in place of the indirect readout arrangements used previously. During the years since, these generators have become widely known and used in the microwave field^{1, 2}.

SEE ALSO:
"Variable-Frequency AC Supply", p. 6

This long experience with microwave signal generators combined with the development of new technological advances

has now given rise to a new generation of -hp- microwave generators. The first of these, the subject of this article, operates over the band from 800 to 2400 megacycles and provides an RF power output that is virtually flat (within ± 0.5 db) over this entire range. The flat output is obtained by an automatic internal leveling system and eliminates the need for readjusting the output power at each change of frequency, thus facilitating many measurements. A flat output also offers other measurement conveniences which are described later.

Besides providing leveled power, the new generator has a special cavity and attenuator design which gives increased maximum output power. Output powers from 10 to 60 mw,

¹Arthur Fong and W. D. Myers, "The -hp- Direct-Reading UHF Signal Generators," Hewlett-Packard Journal, Vol. 3, No. 9-10, May-June, 1952.
²W. D. Myers, "A 3800-7600 Mc Signal Generator Using A Parallel-Plane Type Resonator," Hewlett-Packard Journal, Vol. 2, No. 1, Sept., 1950.

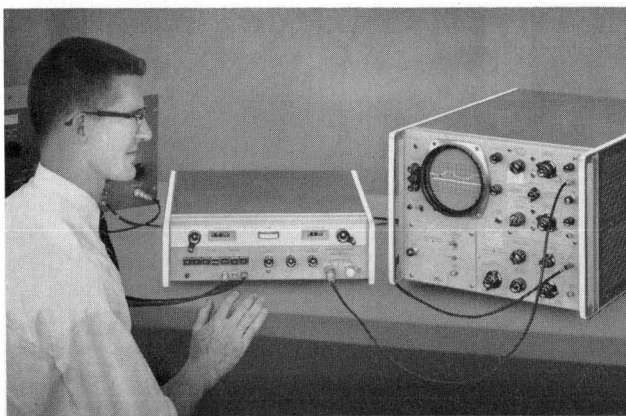

Fig. 1. New -hp- Model 8614A Signal Generator operates from 800 to 2400 Mc and provides outputs up to 10 to 60 mw. Generator is designed to provide leveled output, is also capable of being sine-wave modulated.

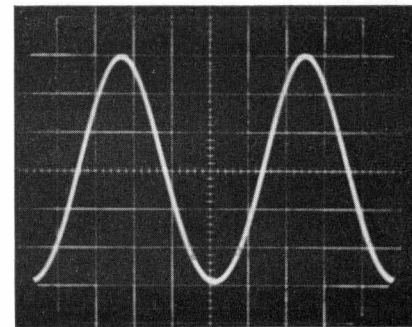

Fig. 2. Oscillograms of modulation envelope obtained when new generator was 30% amplitude-modulated by 10 kc sine wave at carrier of 1,000 Mc.

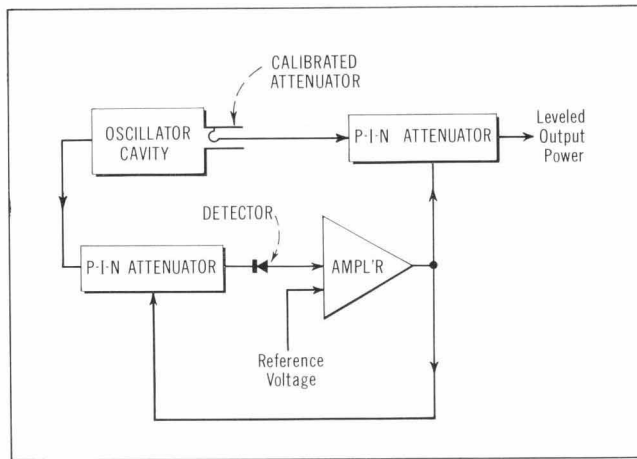

Fig. 3. Basic circuit arrangement of new -hp- Model 8614A UHF Signal Generator.

compared to about 0.5 mw previously available, are provided without sacrificing the accuracy and precision of a piston-type waveguide-beyond-cut-off output attenuator which attenuates the output power to levels as low as -127 dbm.

The modulating and leveling arrangement in the generator is based on the use of newly-developed *p-i-n* diodes in an electrically-controlled absorption modulator. This modulator gives modulation capabilities heretofore unavailable in a microwave generator. For example, the RF output from the generator can be truly amplitude-modulated by sine waves or complex waveforms. All pulse and amplitude modulation, including square wave modulation, is accomplished externally from the klystron oscillator, an arrangement that eliminates the disadvantages associated with directly pulsing an oscillator. Several modes of modulation, AM, FM or pulse, can be obtained,

and they can be obtained simultaneously or separately, and with or without leveling. This flexibility enables the generator to meet a variety of complex modulation requirements.

The panel height of the overall instrument is small, 5¼ inches, and was made possible by linearizing the frequency drive and replacing the previously-used large dial with a digital readout. Linearization not only improves the readability but also facilitates remote frequency programming with servo controls such as the Dymec 2307A Servo Programmer.

CIRCUIT ARRANGEMENT

The oscillator portion of the 8614A Signal Generator consists of a reflex klystron operating with an externally-tunable coaxial cavity. The klystron repeller voltage is automatically tracked when changing the frequency.

Typically, the field strength and hence the output power of a klystron

cavity may vary as much as 15 db across the frequency band (0.8 to 2.4 gc) which covers two klystron repeller modes. Accurately calibrated output power has heretofore necessitated manual "power setting", or the adjusting of a monitoring loop to balance the power output and maintain a constant reading on a bridge meter.

To achieve automatic leveling in this instrument, power is coupled out of the cavity with a well-matched magnetic loop connected to a closed-loop feedback system consisting of a *p-i-n* diode-attenuator, a well-matched crystal detector, and a differential amplifier (Fig. 3). The attenuator is a stripline array of *p-i-n* diodes and is used as a variable-microwave-loss element preceding the detector. Since the RF resistance of the diodes is (inversely) related to the applied forward bias current, the *p-i-n* attenuator behaves as a variable RF attenuator controlled by the amount of current through the diodes. The function of the attenuator is to maintain a constant level at the detector in the closed loop. The same signal that controls this attenuator is also applied to a similar *p-i-n* attenuator-modulator in the main output channel. RF power is fed to this channel from the oscillator cavity by a second coupling loop which operates in a waveguide-beyond-cut-off, piston-type

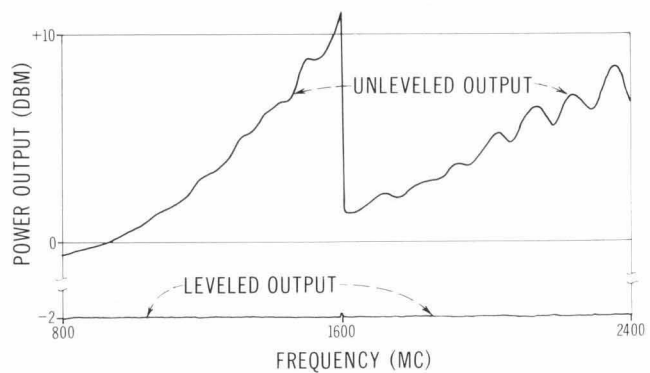

Fig. 5. Recordings of power output from new Generator showing typical effect of leveling (lower trace) on output curve typical of broadband klystrons (upper trace).



Fig. 4. Panel view of -hp- Model 8614A Signal Generator.

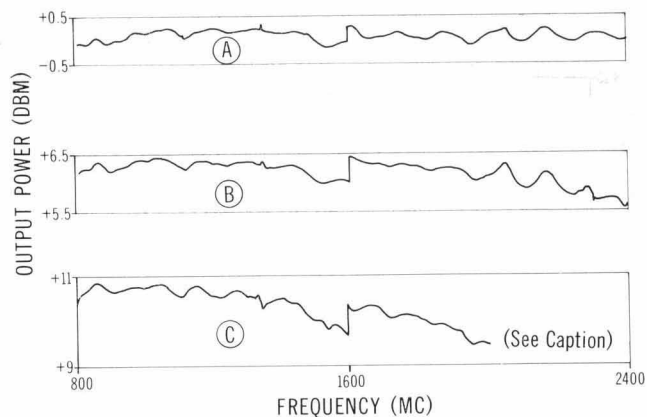

Fig. 6. Expanded-scale recordings showing typical leveled outputs obtainable at rated and above-rated ("B" and "C") leveled powers. Reduced frequency coverage ("C") occurs at higher powers, but usable range is still wide.

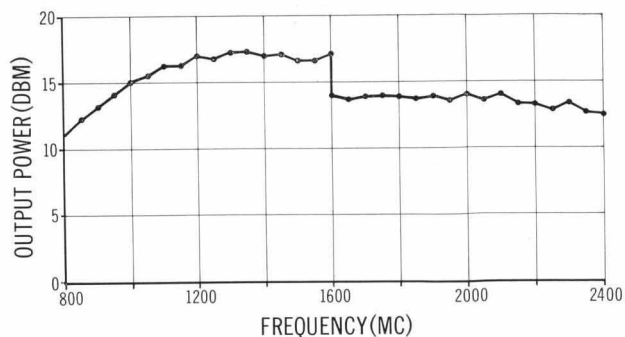

Fig. 7. Curve typical of maximum power output obtainable from new Generator.

attenuator. The leveling of the output power is therefore essentially independent of the attenuator setting, and a leveled output across the frequency band is achieved automatically even at the low power levels of -127 dbm. Power variations across the frequency band are less than ± 0.5 db (see Fig. 5) with this system.

Provision has also been made for leveling by external signals. A jack is provided at the back of the instrument to enable a signal from a negative polarity detector to be fed into the closed loop, replacing the signal from the internal crystal detector.

GREATER MAXIMUM POWER

The new 8614A Signal Generator obtains a greater maximum output power by locating the coupling loop

at the sliding short of the tunable klystron cavity, a point of maximum magnetic field strength. The design of a differential mechanical drive allows the calibrated output loop to move in the piston-type output attenuator mentioned above. Such an attenuator has excellent accuracy and provides a linear attenuation in db down to very low power levels.

When extracting output powers above approximately 0 dbm, the attenuator coupling loop moves out of the cut-off region so that the linearity of the attenuation is lessened by end effects. Hence, at output power levels greater than 0 dbm the attenuator is not calibrated. For this reason leveling is usually established at a level of 0 dbm, as adjusted by the setting of the automatic leveling (*ALC*) control and indi-

cated on the output meter, to retain the calibration of the output attenuator. The leveled output power can be adjusted approximately ± 4 db from the normal calibrated level by adjusting the setting of the *ALC* control which changes the reference voltage of the differential amplifier in the control loop.

Where there is no need for calibrated output power, the coupling loop can be moved into the cavity by means of the panel control to gain maximum coupling. In this way a leveled output of approximately $+6$ dbm can be maintained across the entire frequency band. Over selected narrower frequency bands, where there is sufficient power in the cavity, even higher power outputs can be leveled (Figs. 6b, c).

For obtaining the maximum power output, the bias current on the *p-i-n* diodes is removed by switching off the automatic leveling switch. This allows the RF signal to pass through the stripline with a minimum of loss. The loop is adjusted for maximum coupling by advancing the attenuation control to the point where further penetration into the cavity begins to load the cavity, as indicated by a decrease in the output meter reading. A plot of typical maximum power obtained in this way is shown in Fig. 7.

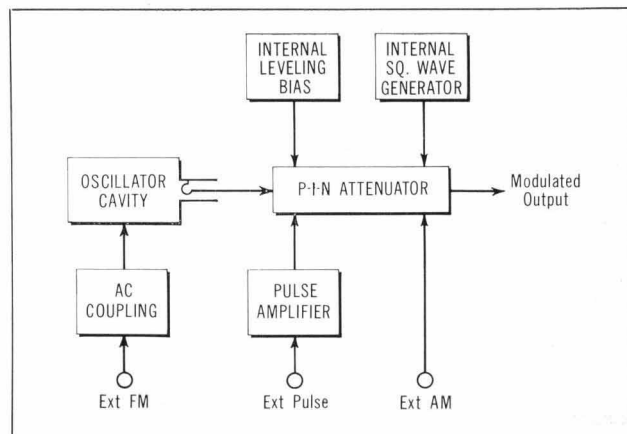

Fig. 8. Use of *p-i-n* attenuator/modulator in new Generator permits any combination of *a-m*, pulse, or frequency modulation and leveling to be obtained.

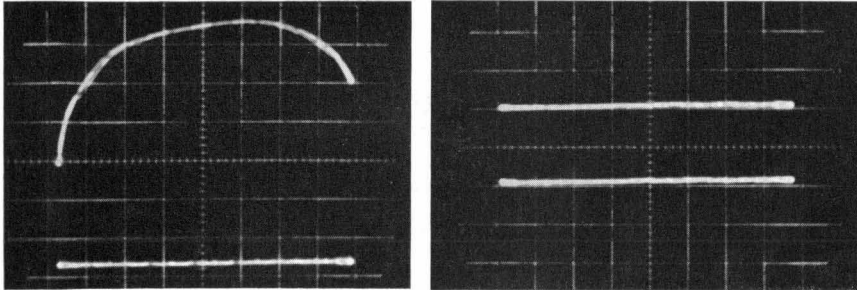

Fig. 9. Oscillograms of detected power output when FM-modulating showing advantage of automatic leveling (right)

compared to no leveling (left) in obtaining constant power output. Lower traces represent zero power level.

MODULATION

The development and availability of a new solid-state modulator of very high performance and versatility, the recently-announced -hp- Model 8714A³, has reduced the need for sophisticated modulation capabilities in the generator itself. This external modulator also makes use of new *p-i-n* diodes to achieve extremely fast, low-jitter RF pulses. Using the modulator, a pulse-modulated RF envelope can be obtained with 20 nanosecond rise and fall times, 0.1 microsecond minimum duration, and much less than 1 nanosecond jitter. The combination of this modulator and the new signal generator will thus provide a high performance system and one that has great flexibility. Consequently, the internal modulation provision included in the generator is only that of a general-purpose square-wave modulator, adjustable from 800 to 1200 cps. External signals can,

however, be applied to obtain a variety of modulations including pulse, amplitude and frequency modulation (Fig. 8).

Frequency modulation is accomplished through a panel connector which couples an external modulating signal to the klystron repeller. The other modulation inputs connect to the stripline of *p-i-n* diodes in the output channel. In all modes of modulation the klystron operates CW so that incidental AM and FM normally associated with the pulsing of a klystron oscillator is essentially eliminated. Incidental FM, for example, is typically 1 part per million.

Furthermore, because amplitude modulation is done with *p-i-n* diode attenuators, all of the modes of modulation can operate simultaneously and with leveling by superimposing the signals on the *p-i-n* diode bias current, i.e., by connecting external AM modulating signals to the *Pulse* and *AM* input connectors and an *FM* signal to the

FM connector. This increased flexibility of modulation has many advantages. For example, simultaneous leveling and frequency modulation provides a much more useful *FM* generator (Fig. 9).

Previously, because modulation was done at the klystron, true amplitude modulation was impossible. The klystron oscillator was either off or on and only square wave modulation could be accomplished. However, the *p-i-n* diode stripline can be used as a continuously-variable attenuator by varying the current through the diode. The attenuation of the stripline varies nearly linearly in db with bias current. Oscillograms showing the resulting sine wave modulation obtainable are shown in Figs. 2 and 11.

FREQUENCY STABILITY

Several measures have been taken to enhance the frequency stability of the new generator. The use of well-regulated klystron power supplies has resulted in a short-term drift stability of less than $5/10^6$ over a fifteen-minute period and a long-term drift stability of $15/10^6$ during an eight-hour period. Turn-on drift, primarily the result of thermal expansion of the cavity, has been held to less than $5/10^4$ for an approximate warm-up period of two hours.

If greater stability is desired, the signal generator can be used with the Dymec Synchronizer (DY-2650A) such that short-term sta-

³Nicholas J. Kuhn, "A New Microwave Modulator," Hewlett-Packard Journal, Vol. 14, No. 7-8, Mar.-Apr., 1963.

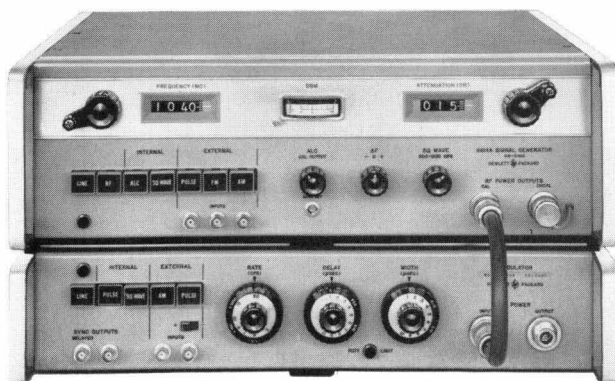

Fig. 10. Generator can be operated with -hp- Model 8714A Modulator to obtain fast-rise RF pulses.

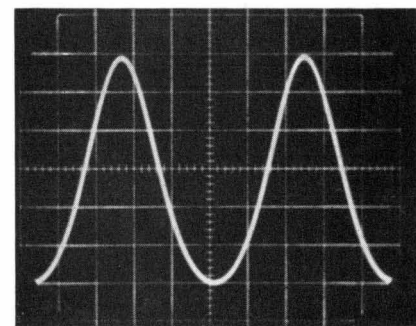

Fig. 11. A-m envelope obtained when Generator was 60%-modulated with external 10 kc sine wave at 1,000-Mc carrier.

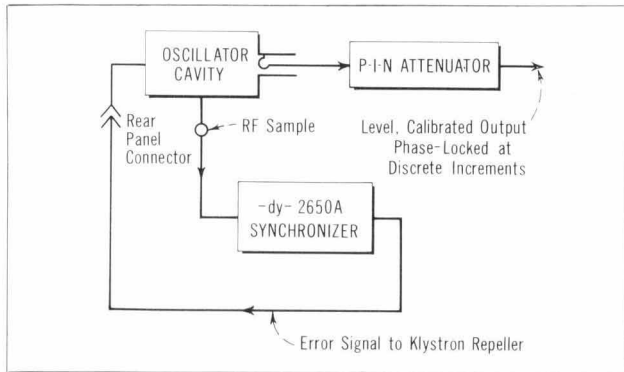

Fig. 12. Dymec 2650A Synchronizer can be used to obtain short-term stabilities of $1/10^8$ from Generator at discrete frequencies.



Fig. 13. Combination of new Model 8614A Signal Generator, 8714A Modulator, and 489A TWT Amplifier comprise high-performance signal generator with output of 1 watt.

bilities of $1/10^8$ can be obtained. The signal generator has a third coupling loop in the cavity to supply an RF sample to the DY-2650A Synchronizer.

RF SHIELDING

Special consideration has been given to the shielding of the new signal generator. Radiated RF energy has been reduced to insure a minimum of interference while operating at very low power levels. Extra precautions have been taken with the calibrated attenuator output cable to keep incidental coupling to this cable below -157 dbm. This limits the ambiguity of the attenuator calibration at -127 dbm to less than ± 0.25 db.

LINEARIZED FREQUENCY DRIVE

The relationship between cavity length and frequency is essentially a hyperbolic function. By linearizing this function mechanically such that the input drive varies linearly with frequency, it was possible to use a digital readout which is calibrated directly in megacycles. This has resulted in the reduction of the panel height to only $5\frac{1}{4}$ inches and at the same time has improved the readability of the dial by providing a least count of 2 megacycles. For very fine tuning of frequency a vernier control on the front panel changes the repeller voltage slightly to give at least a two-megacycle adjustment.

The frequency drive shaft can also be driven from the rear panel and provisions have been made to permit

this to be done with the Dymec DY-2307A Servo Programmer.

The resulting compact design makes the 8614A Signal Generator easy to rack mount. Provisions have been made for all connections to be installed on the rear panel for use in systems where front connections are impractical.

ACKNOWLEDGMENTS

The design and development of the 8614A Signal Generator represent the efforts of many individuals. A number of valuable basic ideas and suggestions were contributed by Dr. George W. C. Mathers. The electrical design and development group included Alan L. Seely, Ronald K. Church, Wayne

A. Fleming, Jerrold M. Hedquist, Ramon L. Sarda and Raymond H. Spoelman. The mechanical design was done by Anthony S. Badger, Fred H. Meyers, and William W. Nelson, and the industrial design, which has won a WESCON award of merit, was by Allen E. Inhelder. The author is indebted to the tool design section of the Microwave Division for the solution of many complex production problems, in particular, to Blair Muhlestein and Harold F. Hampel.

—James R. Ferrell

SPECIFICATIONS

-hp- MODEL 8614A SIGNAL GENERATOR

FREQUENCY RANGE: 800 to 2400 Mc; single, linearly calibrated control; direct reading within 2 Mc.

VERNIER: ΔF control has range of 2 Mc for fine tuning.

FREQUENCY CALIBRATION ACCURACY: ± 5 Mc.

FREQUENCY STABILITY: Approximately $0.005\%/^{\circ}\text{C}$ change in ambient temperature, less than 2500 cps peak incidental FM, less than 0.003% change for line voltage variation of $\pm 10\%$.

RF OUTPUT POWER: $+10$ dbm (10 mw, 0.7 v) to -127 dbm (0.1 μvolts) into a 50-ohm load. Output attenuator dial directly calibrated in dbm from 0 to -127 dbm.

A second uncalibrated RF output (approximately 0.5 mw minimum) is provided on the front panel.

RF OUTPUT POWER ACCURACY: ± 0.75 db + attenuator accuracy (-7 to -127 dbm); ± 3 db (0 to -7 dbm); uncalibrated above 0 dbm. (Includes leveled output variations.)

ATTENUATOR ACCURACY: ± 0.07 db/10 db from -7 to -127 db; direct reading linear readout, 0.2 db increments.

LEVELED OUTPUT: Constant within ± 0.5 db across entire frequency range at any attenuator setting below 0 db. Output power can be adjusted from approximately -4 to $+4$ dbm of the

normal calibrated level with the Automatic Level Control.

INTERNAL IMPEDANCE: 50 ohms, SWR less than 2.0.

MODULATION: On-off ratio at least 20 db for square wave, pulse, and amplitude modulation.

INTERNAL SQUARE WAVE: 800 to 1200 cps. Other frequencies available, on special order.

EXTERNAL PULSE: 50 cps to 500 kc; 1 μsec rise time.

EXTERNAL AM: DC to 1 Mc.

EXTERNAL FM: Mode width between 3 db points varies from a minimum of approximately 4 Mc at a center frequency of 800 Mc to a maximum of approximately 15 Mc at a center frequency of 2000 Mc. Klystron sensitivity is approximately 100 kc/volt between 800 and 1600 Mc ($1\frac{3}{4}$ mode) and 200 kc/volt between 1600 and 2400 Mc ($2\frac{3}{4}$ mode).

(a) Front panel connector capacity-coupled to repeller of klystron.

(b) Two-terminal rear panel connector is dc-coupled to repeller of klystron.

POWER SOURCE: 115 or 230 volts $\pm 10\%$, 50 to 60 cps, approximately 125 watts.

DIMENSIONS: $16\frac{3}{4}$ " wide, $5\frac{1}{2}$ " high, $16\frac{3}{8}$ " deep behind panel. Mounting brackets supplied for 19" wide rack mounting.

RACK MOUNT: 19" wide, $5\frac{1}{4}$ " high, $16\frac{1}{4}$ " deep behind panel.

WEIGHT: Net, 48 lbs; shipping, approximately 63 lbs.

PRICE: -hp- Model 8614A, \$1650.00.
Prices f.o.b. factory
Data subject to change without notice.

A VARIABLE-FREQUENCY AC POWER SUPPLY FOR GENERAL-PURPOSE TESTING

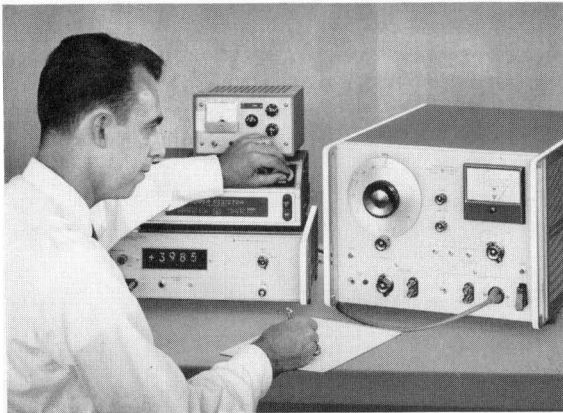

Fig. 1. Hewlett-Packard Model 4301A Variable Frequency Power Supply furnishes up to 250 volt-amperes at frequencies from 40 to 2000 cps. Output voltage is continuously adjustable from 0 to maximum of 130 or 260 volts. Unit also can serve as excellent line isolator.

MANY applications exist that require tests of equipment and devices at unusual power line frequencies or over a range of line frequencies and at various line voltages. Such applications include powering aircraft equipment during development, testing transformers, testing power filter, and testing equipment for overseas operation.

For applications such as these, a new variable-frequency ac power supply has been developed. The new supply generates up to 250 va throughout a frequency range from 40 cps to 2000 cps. It can drive at full volt-ampere output both resistive loads and reactive loads having as much as 0.7 lead or lag power factor. To obtain tight voltage regulation from no load to full load, its effective source impedance is adjustable to zero for specific loads.

The output voltage, monitored by a meter, is selected by front panel controls. Secondary windings on the output transformer can be changed from series to parallel operation by a front panel switch so that full power output is reached at either 260 v (~1 amp max) or 130 v (~2 amps max).

The 4301A may also be driven by

an external signal in the 40-2000 cps band. This ability is of special significance when the 4301A is used to power shake tables or in other applications where it can serve as a power amplifier.

The flexibility of the 4301A is such that it can drive any reactive load. Loads having less than 0.7 power factor, though, require a volt-ampere output derating, as discussed later. The internal positive feedback, which obtains the effective zero output impedance, is made adjustable from the front panel so that a variety of load reactances may be accommodated.

CIRCUIT DESCRIPTION

Conceptually, a variable frequency power supply is a high power, low frequency signal source in a master oscillator-power amplifier configuration (Fig. 2). The oscillator circuitry of the 4301A is similar to the well-known -hp- Wien bridge RC oscillators. Output frequency, selected by the large tuning dial, is accurate to within 1% of the dial setting.

The power output stage is a Class AB, push-pull amplifier whose quiescent plate current was chosen for best balance between output power and distortion. This balance is maintained despite tube aging by individual tube biasing controls on the front panel; the front panel meter can be switched to monitor the current in either output tube for this adjustment.

The power-amplifier driver contains a phase splitter, voltage amplifier and cathode-followers. Cathode-follower drive is used for the output stage so that grid current and its attendant instability will not be a problem.

OUTPUT CONSIDERATIONS

The basic form of the power amplifier, the heart of the instrument,

Fig. 2. Block diagram of -hp- 4301A Variable Frequency Power Supply. External signal may be used in place of oscillator signal.

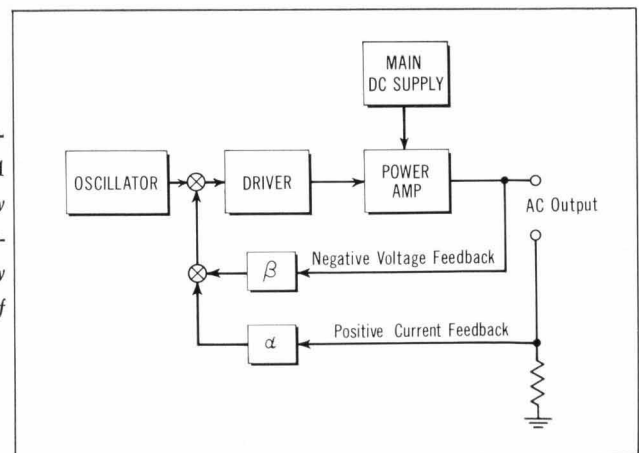

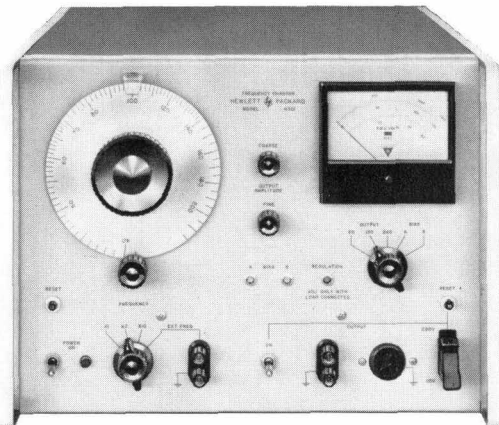

Fig. 3. -hp- Model 4301A Variable Frequency Power Supply. Panel meter monitors output voltage and cathode current in each power output tube to facilitate balancing of push-pull output stage.

is shown in Fig. 4. Although similar to low-distortion audio amplifiers, this one is required to accommodate a variety of loads. The load reflects itself into the output circuit and affects the position of the load line, which in turn determines the maximum permissible output power from this amplifier.

The turns ratio of the output transformer was selected to present a high impedance load to the transmitting output tubes when the instrument is used for low impedance resistive loads. This results in load line A, shown in Fig. 5. This load line has a wide voltage swing but a low maximum to minimum current ratio, which obtains better output regulation as a function of load than would a high max-min current ratio. Also, the relatively low maximum current allows sufficient reserve for tube aging, as well as furnishing a margin for high peak demand currents.

This last requirement is explained by the oscillogram of Fig. 6, which shows the input voltage and current waveforms of a typical electronic instrument using capacitor input filters in the power supply. The load line for this type of load is shown as line B in Fig. 7, with resistive load line A dotted in for comparison.

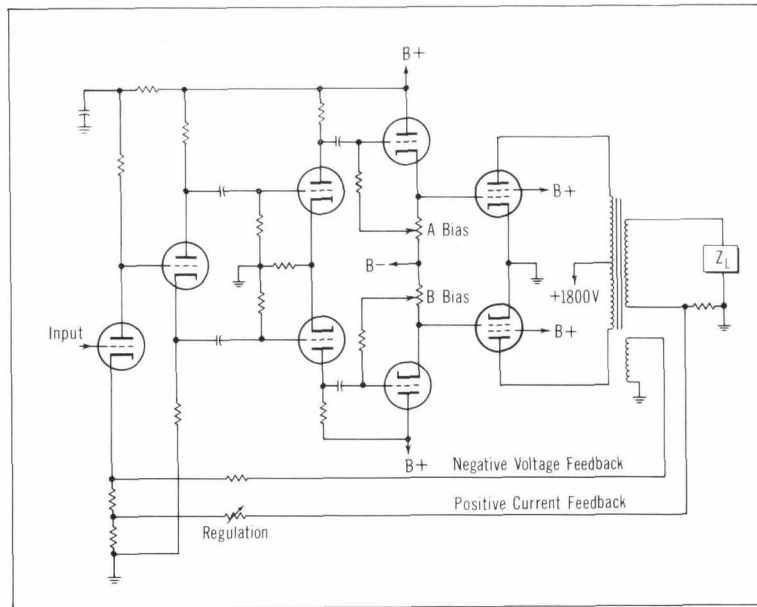

Fig. 4. Circuit diagram of 250 va power amplifier. Transformer output winding actually consists of two windings that may be switched from front panel for either series or parallel operation.

Although the 4301A has a maximum continuous output current rating of 2 a rms sine wave current (at 115 v) into a resistive load, it can easily handle a larger peak current without excessive plate dissipation.*

Loads having power factors of less than unity, including pure reactive loads, alter the load line in a manner which increases plate dissipation without increasing a particular volt-ampere level. Fig. 8 shows a 250 va load (125 va per tube) with 0.7 power factor (line C) and, for comparison, a 100 va reactive load with

*2 amps rms in the transformer secondary windings in parallel corresponds to peak currents of 0.36 amperes in each output tube.

0 power factor (line D.) While maximum plate dissipation is exceeded instantaneously over a portion of the ac cycle, line C is below rated value when averaged over the cycle. Line D, although representing a load of only 100 va, exceeds rated dissipation. This demonstrates why the 4301A is derated for loads having power factors of less than 0.7.

FEEDBACK AND REGULATION

In addition to the usual negative voltage feedback (β of Fig. 2), positive current feedback (α) is incorporated to reduce the source impedance to zero for resistive or near resistive loads.

Fig. 5. Load line (A) for rated maximum resistive load shown plotted on plate characteristics of one power output tube. One grid line is shown for reference.

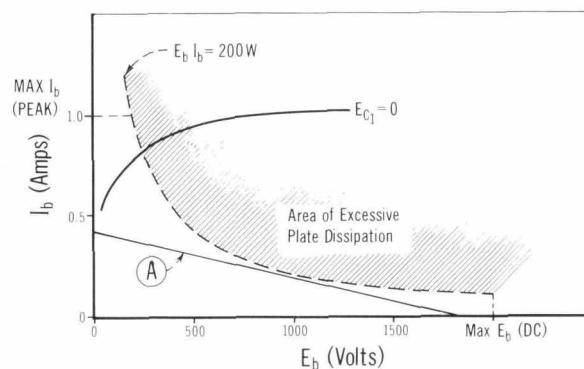

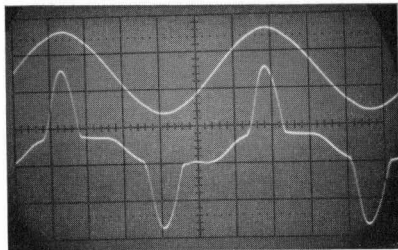

Fig. 6. Dual-trace oscillogram shows ac voltage input to electronic instrument using typical rectifier-capacitor power supply (upper trace). Lower trace shows waveform of input current.

Positive current feedback offers the advantage of permitting relatively low $A\beta$ (10) for negative feedback (loop gain control to 4 cps and 50 kc), while the amount of current feedback necessary to reduce the effective internal impedance to zero does not appreciably influence the ability of the voltage feedback to reduce distortion.

The foregoing remarks apply specifically to resistive loads where both α and β can be assumed to be real quantities. With reactive loads, however, α must be treated as a complex quantity related to the phase angle of the current in the load. While the complex relationship is not serious enough to cause instability, it does cause waveform deterioration.

To accommodate a variety of loads, therefore, the control for α , labelled "Regulation", is brought to the front panel of the 4301A. The

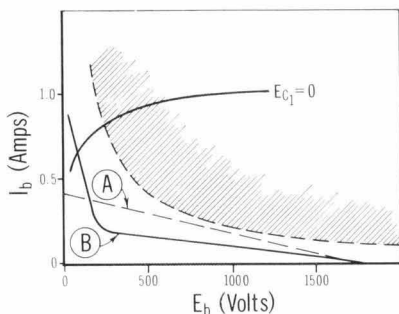

Fig. 7. Load line (B) resulting from load which draws current waveform shown in Fig. 6.

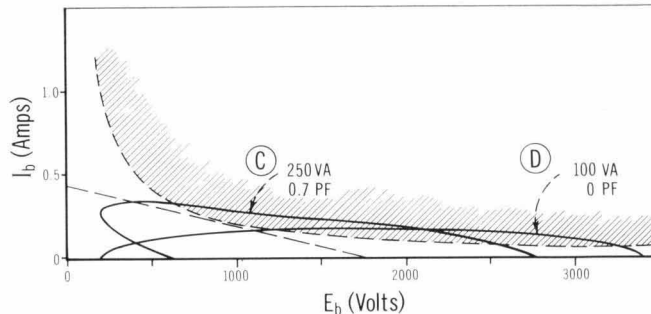

Fig. 8. Reactive load lines illustrate necessity for derating output power when instrument drives loads having power factors of less than 0.7.

user can obtain zero output impedance for near resistive loads by setting this control so that the same output voltage is indicated on the front panel meter with the load connected as that which is shown with the load switched off. Or, he may reduce the positive current feedback when the supply is used with highly reactive loads.

ACKNOWLEDGMENT

The special output transformer of the *-hp-* 4301A variable frequency power supply was designed by Floyd L. Pruitt. Albert C. Knack did the mechanical layout and the under-designed performed the circuit design. The assistance of Dr. B. M. Oliver in solving loop stability problems is greatly appreciated.

—Duane P. Lingafelter

Negative Real-Part Impedances and the Smith Chart

ACKNOWLEDGMENT

Prof. Howard Boyet of the Pratt Institute has generously advised us of an earlier work on the subject of plotting negative real-part impedances on the Smith Chart, a subject discussed in our Mar.-April, 1963, issue.¹

The earlier work was that of Dr. Bernard Rosen and appears in the letters section of the September, 1960, issue of the Proceedings of the I.R.E.² We are glad to bring Dr. Rosen's significant and interesting work to the attention of our readers and regret that it was not located in our original literature search.

¹"Using the Smith Chart with Negative Real-Part Impedances or Admittances," Vol. 14, No. 7-8, Mar.-April, 1963.

²"Transformation of Impedances Having a Negative Real Part and the Stability of Negative Resistance Devices," Proc. I.R.E., Vol. 48, No. 9, Sept. 1960, p. 1660.

SPECIFICATIONS

-hp- MODEL 4301A VARIABLE FREQUENCY POWER SUPPLY

OUTPUT POWER MAXIMUM: 250 volt-amperes.
OUTPUT VOLTAGE: Two ranges; 0-130 v (2 amps max at 125 v), 0-260 v (1 amp max at 250 v).
OUTPUT CURRENT: Maximum current is proportional to output voltage, e.g. 2 amps at 125 v, 1 amp at 62.5 v, etc.
LOAD POWER FACTOR RANGE: 1.0 to 0.7 lead or lag at full power; derated for less than 0.7 pf.
FREQUENCY RANGE: 40 to 2000 cps.
ACCURACY AND STABILITY: $\pm 1\%$.
EXTERNAL FREQUENCY INPUT:
FREQUENCY RANGE: 40 to 2000 cps.
VOLTAGE: Approximately 2.5 v for maximum output.
INPUT IMPEDANCE: Greater than 20 k.
HUM AND NOISE: More than 65 db below rated output.
HARMONIC DISTORTION:
RESISTIVE LOAD: Less than 1.5%.
0.7 P.F. LOAD: Less than 5%.

OPERATING TEMPERATURE RANGE: 0 to $+55^\circ\text{C}$.

OUTPUT REGULATION VS. RESISTIVE LOAD*: Better than $\pm 1\%$ or ± 1 v (whichever is greater) with front panel REGULATION control fully clockwise. Can be set to give 0% for a given load.

OUTPUT REGULATION VS. LINE: Better than $\pm 1\%$ for $\pm 5\%$ line voltage changes at 250 va or less. Better than $\pm 1\%$ for $\pm 10\%$ line voltage changes at 190 va or less.

OUTPUT RECOVERY TIME: Less than 0.5 second for no load to full load change.

INPUT POWER: 115 v or 230 v $\pm 10\%$, 50 to 60 cps, 500 to 750 watts.

DIMENSIONS: 12½ in h by 16¾ in w by 24¾ in d. Hardware furnished for quick conversion to rack mount.

WEIGHT: Net 124 lbs, shipping 150 lbs.
ACCESSORIES AVAILABLE: 1115A Testmobile, \$115.00.

PRICE: \$1350.00.

*For a reactive load of 0.7 power factor, regulation is typically $\pm 5\%$ or ± 5 v (whichever is greater), depending on exact nature of load, setting of Regulation control, and frequency of operation.

Prices f.o.b. factory
 Data subject to change without notice.